

## Road Light Instruction manual

For retention and reference

- Installation of this product/ luminaire must be carried out by a qualified electrician in accordance with the national, local electric and construction codes and regulations. Installation by unqualified person is prohibited by law.

Product Name	Light Color	Power	Rated voltage	Rated Current	Power factor
LLF0016A/LEN△/56/C/IN/100 LLF0016A/LEN△/56/C/IN/100/NC	3000K	100W	100~240V 50Hz	100V 1.00A 240V 0.42A	0.96
LLF0016A/LEN△/56/C/IN/□ LLF0016A/LEN△/56/E/IN/□	3000K	117W		100V 1.17A 240V 0.49A	
	4000K				
LLF0016A/LEN△/64/C/IN/□ LLF0016A/LEN△/64/E/IN/□	3000K	134W		100V 1.40A 240V 0.56A	
	4000K				
LLF0016A/LEN△/72/C/IN/□ LLF0016A/LEN△/72/E/IN/□	3000K	150W		100V 1.50A 240V 0.63A	
	4000K				
LLF0016A/LEN△/76/C/IN/□ LLF0016A/LEN△/76/E/IN/□	3000K	158W		100V 1.58A 240V 0.66A	
	4000K				
LLF0016A/LEN△/80/C/IN/□ LLF0016A/LEN△/80/E/IN/□	3000K	167W		100V 1.67A 240V 0.70A	
	4000K				
LLF0016A/LEN2/96/C/IN/L1P1W140	3000K	140W	220V 50Hz	220V 0.67A	
LLF0016A/LEN2/96/C/IN/L1P1W176		176W		220V 0.84A	
LLF0016A/LEN△/96/C/IN/□ LLF0016A/LEN△/96/E/IN/□	3000K	202W	100~240V 50Hz	100V 2.02A 240V 0.84A	
	4000K				
LLF0016A/LEN3/96/C/IN/L1P2W205	3000K	205W	220V 50Hz	220V 0.97A	
LLF0016A/LEN3/96/C/IN/L1P2W226		226W		220V 1.07A	

△...1, 2, 3 or 4    □...A or NC

Item	Value
Overall dimensions	734mm × 313mm × 151mm
Weight	10kg
Maximum projected area	0.198 m <sup>2</sup>
IP classification	IP66
IK classification	IK08
Operation temperature	-20~50℃
Mounting height	6~14m
Compatible pole	Φ60.5mm (Length ≥135mm) ※Side-entry

- This product is classified as Class I luminaire.
- For outdoor use only.
- The light source contained in this luminaire shall only be replaced by the manufacturer or his service agent or a similar qualified person
- LED has dispersion in brightness and light color. The product may have different light color and brightness even among products with the same model number.
- Please note that unevenness of the projected light may be noticeable depending on the irradiation distance or the condition of the irradiation surface.

## Attention at installation

**WARNING**

Incorrect handling of this product may cause serious personal injury, death and damage to the product and property.

- This product must be installed in accordance with the installation instructions to avoid malfunction, fixture fall, electrical shock or fire.
- This product is only for general outdoor or general indoor use.
- Do not use the product in the following environment or situation. It may cause fall of the fixture, electric shock or fire.
  - Places where the humidity exceeds 90% RH or the product is covered with water.
  - Places where vibration or shock are transmitted to the fixture, e.g. where the crane is installed.
  - Places where fixtures are directly exposed to organic solvents (acetone, ethyl ether, hexane, etc.)
  - Places filled with corrosive gas (hydrogen sulfide, ammonia, etc.) and flammable gas (hydrogen, methane, propane, etc.)
  - Indoor pools where chlorine is used.
  - Places where flammable liquid (gasoline, kerosene, heavy oil, etc.) is used.
  - Places where there is much oil mist, e.g. metal working plants, kitchens, etc.
  - Place with much mine dust.
  - Places covered with heat insulating materials or combustibles.
  - Places where fixtures are buried in snow.
- Do not disassemble or modify the fixture. It may cause fall of the fixture, electric shock or fire.
- Do not remove the vent filter and give shock to the fixture to avoid water intrusion.
- Do not operate the product when it is damaged. It may cause fall of the fixture, electric shock or fire.
- If there are abnormalities found in the product such as smoke or unusual odor, disconnect power immediately and contact dealers.
- Use the fixture within the specified input voltage range.
- Please perform class D grounding work(100 ohms and below) for the ground wire.  
Failure to perform grounding work may cause a fire or electric shock.

**CAUTION**

There is a possibility that it is assumed to owe injury.

- This product is only for general outdoor use. It cannot be used anywhere else. It may cause a fall, electric shock, or fire.
- A high brightness LED is used as a light source. Do not look directly at the light source (LED).
- The wind pressure resistance is 52 m/s. Do not install in places where the wind speed exceeds it to avoid fall of the fixture.
- The product must be used with the specified input voltage and frequency.
- Use the fixture within the specified operating temperature. During the daytime, do not use it except for temporary operation check.  
Failure to comply with them may reduce the life of the fixture and cause electrical shock or fire.
- When the product is used in cold areas, do not install in places where icicles can fall.
- Do not install the product in places containing sulfur component such as hot spring.
- Do not install the light source of this product in a place where people can keep looking at it for a long time.
- Do not intentionally touch or remove the vent filter or cable gland. It may impair waterproofness.
- Observe the following installing conditions when installing this product.

**PART NAME**

Cover Glass  
(Fixing Screw, ※Don't loosen screw)

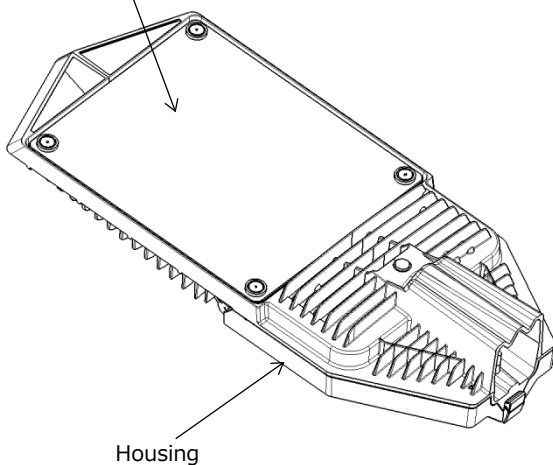

Housing

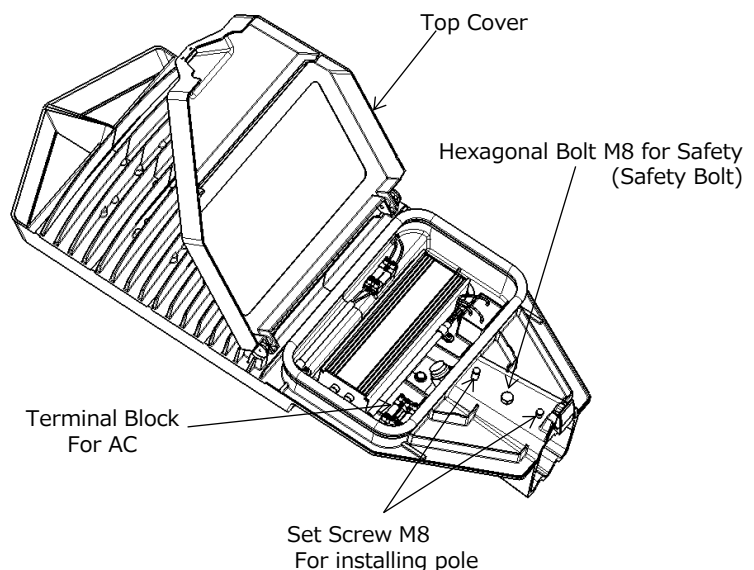

Top Cover

Hexagonal Bolt M8 for Safety  
(Safety Bolt)Terminal Block  
For ACSet Screw M8  
For installing pole

## Check The Pole Adapter

Please process according to the following because it will cause the instrument to fall.

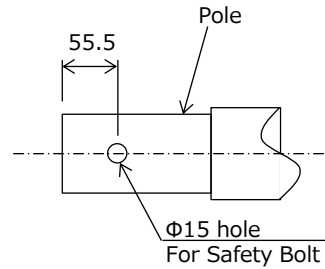
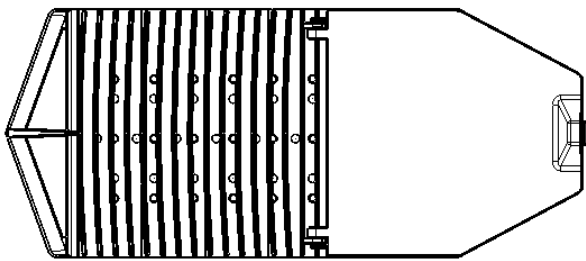

## Installation procedure

### 1. Open cover

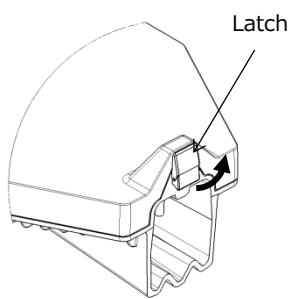

Open Latch

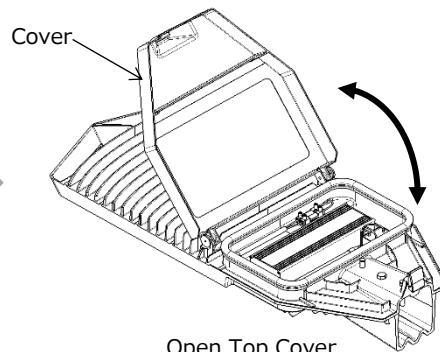

Open Top Cover

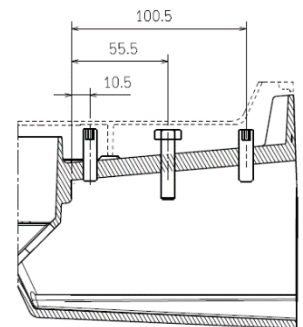

Section : Housing Bolt / Screw Layout

### 2. Install pole by set screw M8.

Recommended set screw M8 torque : 12.5 N·m

#### 2.1 Move the Hexagonal Bolt M8 up.

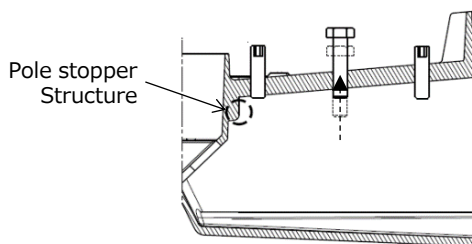

#### 2.2 Insert pole to Housing

Bring the pole into contact with the pole stopper

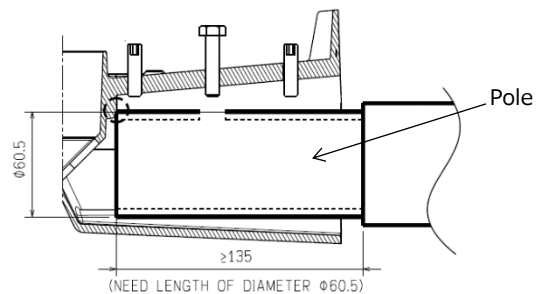

#### 2.3 Fix the pole by tightening Set Screw M8

Recommended Set Screw M8 torque : 12.5 N·m

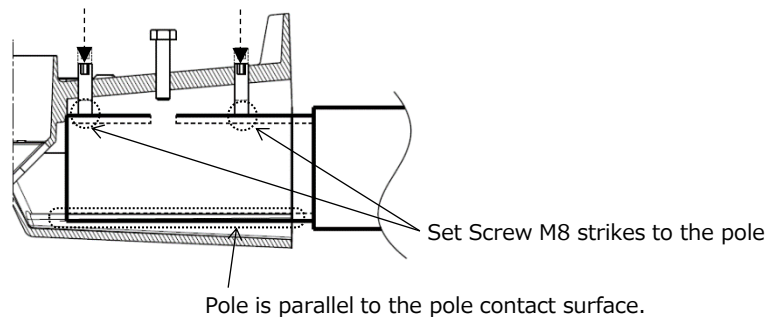

3. Install Hexagonal Bolt M8 for safety to  $\Phi 15$  hole of housing.  
Recommended Hexagonal Bolt M8 torque : 12.5 N·m

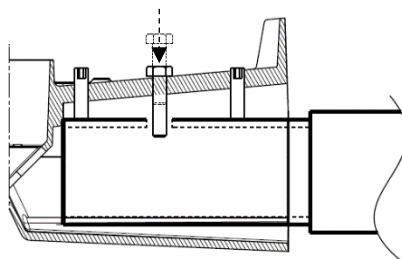

## Electrical wire connection method

1. Install AC line cable to Cable gland by tightening the Cable gland.  
Recommended torque of Cable gland : 2.2 ~ 3.0 N·m

### Requirement of input AC line cable

- Conductor of wire : 2.5 mm<sup>2</sup>  
3-Core : L(R/S/T), N, G
- Available cable sheath size :  $\Phi 6 \sim \Phi 11$ mm

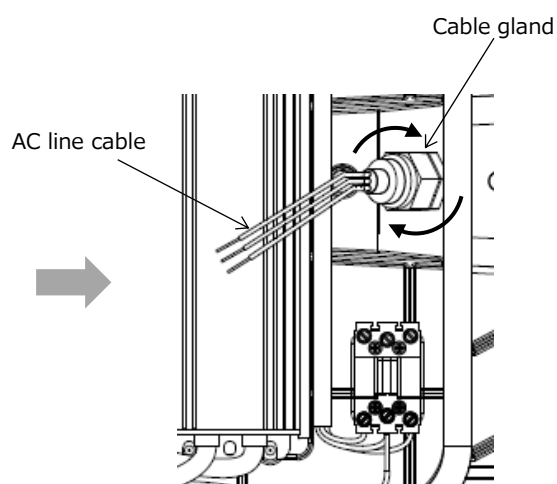
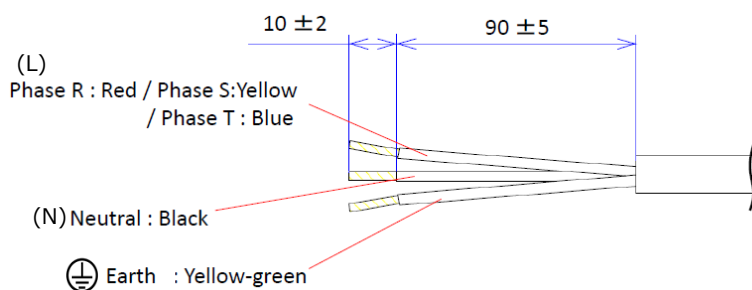

2. Connect wire of AC line cable to Terminal Block(Female)

- 2.1 Use "+" driver to unscrew M3  
2.2 Pull out Terminal Block (Male)

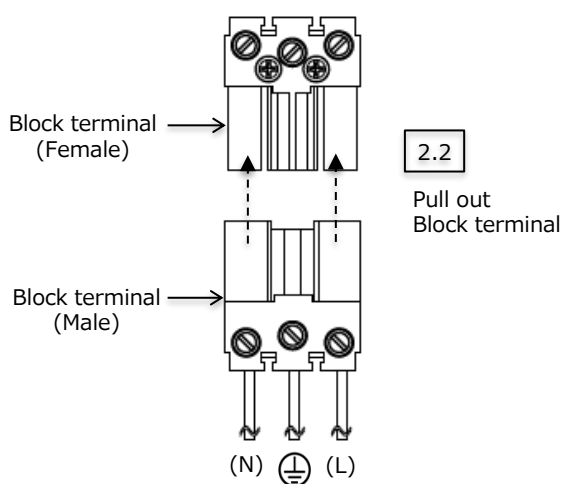
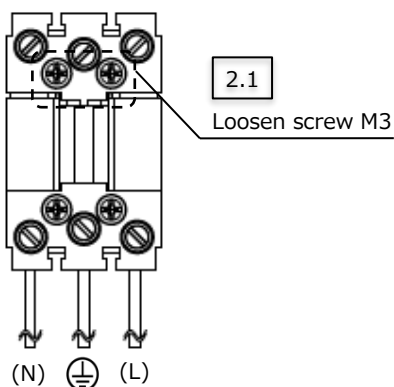

2.3 Connect AC line cable to Terminal Block (Female) by using "-" driver  
Recommended screw torque : 2.0 kgf·cm

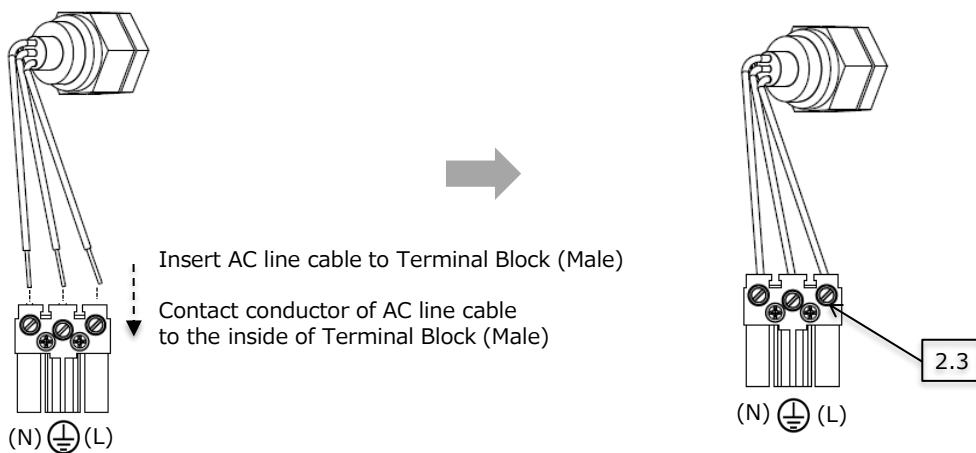

2.4) Assembly Terminal Block (Male) to Terminal Block (Female) by push together until tight.  
2.5) Fix Block terminal with housing by using screw M3  
Recommended screw M3 torque : 6.0 kgf·cm

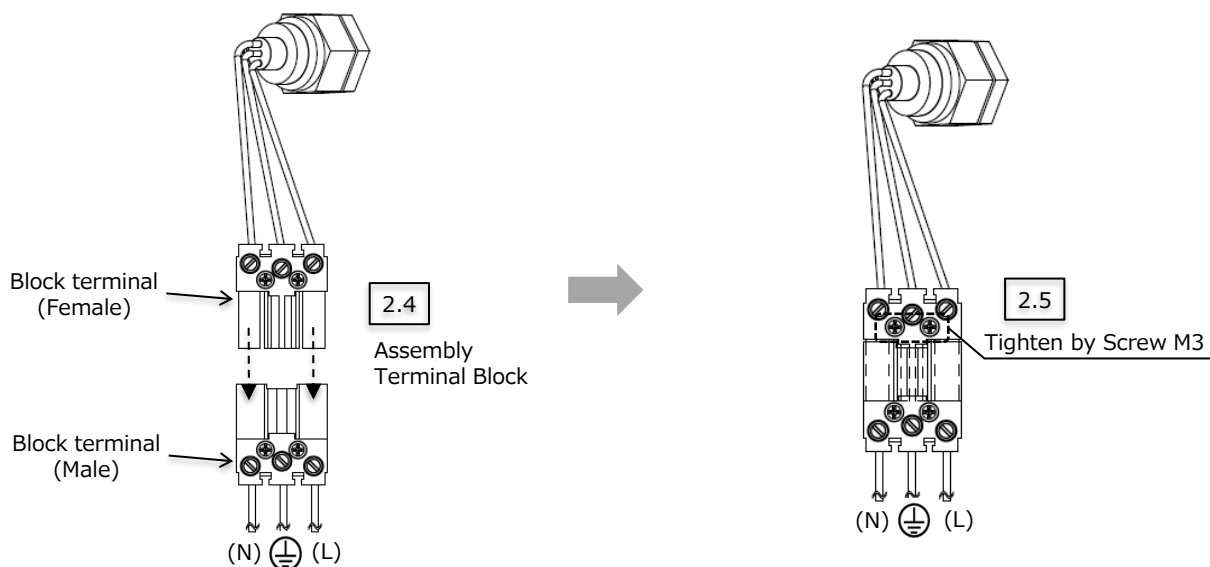

3. Check rubber that must be in a right position.

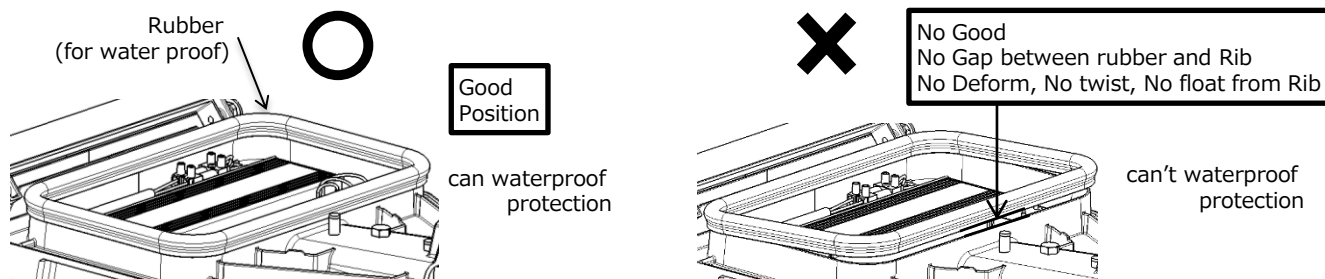

4. Close cover and lock Latch

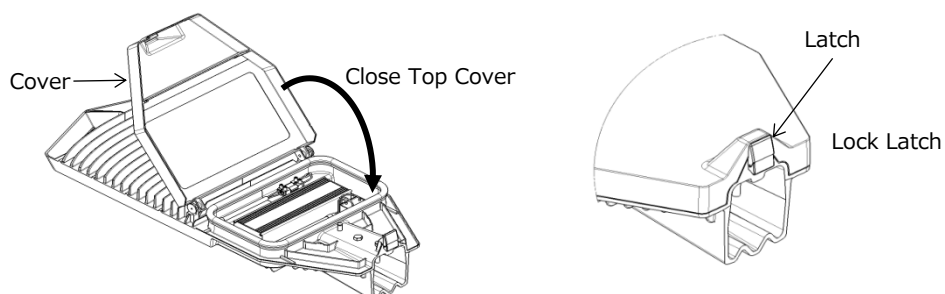

## **Design Attitude**

Install as shown below.

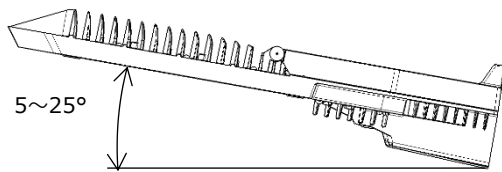

## **Fall prevention wire&clamp**

Only the following products

- LLF0016A/LEN2/96/C/IN/L1P1W140
- LLF0016A/LEN2/96/C/IN/L1P1W176
- LLF0016A/LEN3/96/C/IN/L1P2W205
- LLF0016A/LEN3/96/C/IN/L1P2W226

Attach the fall prevention wire to the pole as shown below.

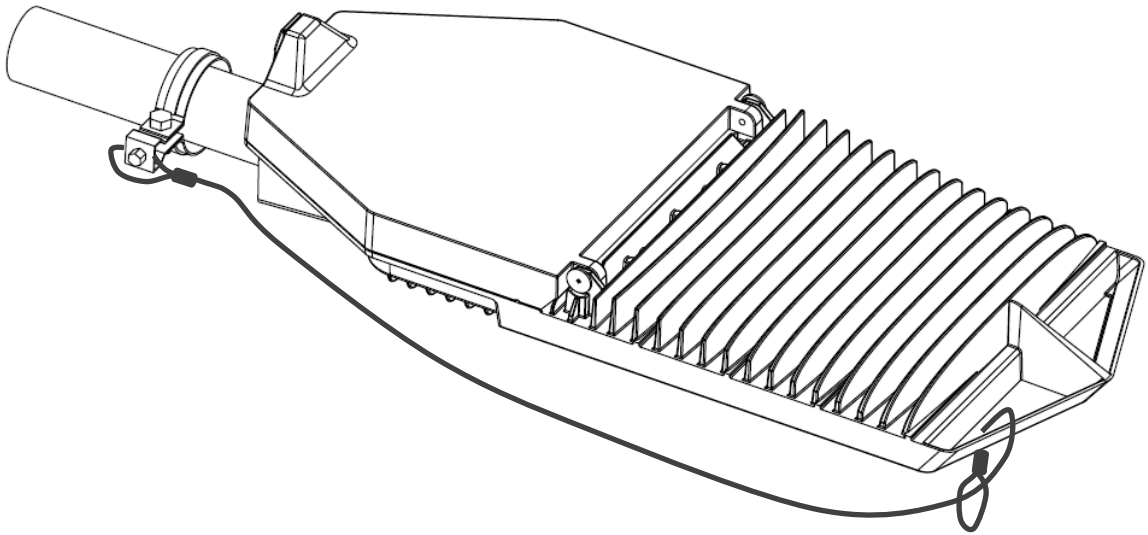

## 取扱説明

お客様へ、この説明書は必ず保管下さい

Handling instructions

Dear customer, please retain this instruction manual.

## 使用上のご注意 / Handling notes



## 警告 / WARNING

取扱を誤った場合、人が死亡または重症を負う可能性があります

Incorrect handling of this product may cause serious personal injury, death and/ or damage to the product and property.

- お手入れの際は、取扱説明書に従って行って下さい。落下、感電、火災の原因となります。  
When servicing this luminaire, please strictly follow the instructions in the manual.
- お手入れの際は、必ず電源を切って行って下さい。感電の原因となります。  
Always turn OFF the power before performing and maintenance.
- お客様での修理や分解、改造は絶対にしないで下さい。落下、感電、火災の原因となります。  
Do not disassemble this product, repair or replace any of its components. - Risk of electric shock, fire or the product fall.
- 光源には高輝度LEDを使用しています。光源部を直視しないでください。  
This luminaire uses high bright LED. Do not look directly at light source, it may harm your eyes.



## 注意 / CAUTION

取扱を誤った場合、傷害を負うことが想定される可能性があります

Risk of personal injury when the product is not handled correctly

- お手入れの際は、必ず電源を切って製品が十分に冷えてから行ってください。火傷の原因となります。  
Always turn off the power supply and allow the product to cool sufficiently before performing any maintenance
- 周囲温度が高い場合は、寿命が短くなります。  
At higher ambient temperature, life span will be shortened.
- 寿命期間内でも異常を感じた場合は、すぐに電源を切って販売元へ連絡してください。  
異常が生じた状態で使用すると火災や感電の原因となります。  
When abnormality occurs, turn off the power immediately and contact your distributor for assistance. Continued use of the product risks electric shock and fire.
- 施行時の一時的な点灯確認以外では日中に点灯させないでください。  
照明器具が直射日光によって温められている状態なので、点灯により器具内部温度が上昇します。  
Please do not light up during daytime, except for lighting checks and confirmation.  
The internal temperature of the luminaire will rise if operate under direct sunlight.
- 積雪地域でご使用する場合は、雪に埋もれないように除雪してください。  
When using in snowy condition, please clear snow to prevent the luminaire from being buried in snow .
- レンズ部に汚れが付着すると暗くなりますので、1年に1回の自主掃除を推奨致します。汚れを拭き取ると明るさは元に戻ります。  
It is recommended to clean lens annually. Brightness is reduced when dirt adhered to the lens.  
The brightness will return to the original state when the dirt is wiped off.
- 安全に使用するために、1年に1回は自主点検をおこなってください。  
Please inspect the luminaire once a year to ensure safe usage.
- 3年に1回は工事店など専門家による点検をおこなってください。  
(3年以上経過したものについては入念に点検をおこなってください。)  
異常状態のまま使用しますと発煙・発火、感電、又は落下の原因となることがあります。  
Please have the luminaire inspected by a specialist, such as an electrical contractor once every 3 years.  
(The luminaire requires thorough inspection when used for 3 years or more. )
- LED素子にはバラつきがあり同一型番の照明器具においても光色、明るさが異なる場合がありますのでご了承ください。  
Please understand that the color and brightness may differ between luminaires even for the same model because of variation in LED chips.

## お手入れについて / Care for your equipment

- 器具お手入れの際は、必ず電源スイッチを切ってください。  
消灯直後は器具が高温となっていますのでしばらく（20～30分程度）時間を置いてから行ってください。  
Be sure to turn off the power before performing any cleaning.  
As the product may be hot after switching off, please wait for a brief interval(20～30 minutes) before cleaning.
- 器具の外側面やカバーの外側の汚れを落とす場合には、柔らかい布を水あるいは中性のせっけん水に浸し、よくほってからふきとってください。  
To wipe off dirt on the surface of equipment or cover, use a damp soft cloth  
(Squeezed off after soaking in water or Neutral soap water).
- シンナー、ベンジンなどの揮発性のもの、酸・アルカリ系洗剤で拭かないで下さい。変色、変形の原因となります。  
Please do not wipe with thinner, benzene acid, or alkali detergent. It will cause discoloration and the deformation.
- ホースなどで直接器具に水をかけないでください。また、モップやデッキブラシなどを用いた清掃を行わないでください。  
器具内への浸水や器具の破損の原因となります。  
Do not spray water directly on the luminaire with a hose, or clean with a mop or floor brush etc...  
It can cause water ingress and or damage to the luminaire.

## 保証について / Warranty

- 納入後すみやかに御社で受入検査を行い、良否の判定を実施願います。  
特別な問題提起がない場合には品質確認が実施され、受入検査に合格したものと判断させていただきます。  
After receiving, please perform an acceptance inspection promptly and verify the product performance.  
If we do not receive report of any problem, we would assume that the product has passed your acceptance inspection.
- 保証期間は、保証書に記載している期間をご確認ください。  
保証については納入単品での保証であり、交換作業に伴う作業人賃・損害補償などの費用請求についてはご容赦ください。  
The warranty period is stated in the warranty card. We warrant the product is free from defects in manufacturing, materials and workmanship. We may replace your defective product with a similar or improved product at our option.  
In no event shall we be liable for any special, incidental, consequential or indirect damages.
- 故障発生が下記に示す要因の場合については保証の対象外とさせていただきます。  
The warranty does not cover the followings:
  - ① お取り扱い上の不注意及び誤使用による故障  
Failure caused by improper handling and/or misuse.
  - ② 改造やお客様個人で修理をされた場合による故障  
Failure caused by alteration to the product and repair by any authorized person.
  - ③ 不当な使用環境下及び条件での使用で生じた故障  
Failure caused by operating in environment and conditions, outside the product specifications.
  - ④ 天災（火災・地震・台風）等によって生じた故障  
Failure caused by the natural disasters (Fire, Earthquake, Typhoon, etc.)
  - ⑤ 本仕様書の使用・保存温度条件を逸脱した場合に発生した結露による故障  
Failure caused by dew/ condensation when in operation/ storage temperature and conditions outside the product specifications.
  - ⑥ 雷を含む過大な電圧サージなどの電氣的ストレスによって生じた故障  
Failure caused by electrical stress such as excessive voltage surge, including lightning.
- 故障発生の原因が限定出来ない場合には、両社間協議とさせていただきます。  
When the root cause of failure could not be determined, both parties should negotiate in good faith for a settlement.
- 本製品の用途は照明用光源を意図しています。  
弊社が意図した用途以外でご使用されそのことにより発生したあらゆる損害について弊社では一切責任を負いません。  
This product is intended as a light source for illumination applications. We do not assume any responsibility for any damages caused operating the product outside its intended use.

## 交換を依頼されるとき / For replacement

- 保証期間中は、納入日を特定できるものを添えてお買い上げの販売店（工事店）までお申し出ください。  
During the warranty period, please produce the proof of purchase date to the distributor(constructor)
- 保証期間を過ぎている時はお買い上げの販売店（工事店）にご相談ください。  
ご希望により有料にて交換させていただきます。  
When the warranty period has expired, please consult your distributor(constructor) for replacement.  
At your request, we will replace the product at your cost.
- アフターサービスについてご不明な点並びに交換に関するご相談は、お買い上げの販売店（工事店）または下記の弊社窓口にお問い合わせください。  
その際は器具の品名、お買い上げ時期をお忘れなくお知らせください。  
For after-sales service, queries, consultation and replacement, please contact the distributor from which the product was purchased or contact us.  
At that time, please inform us of the name of the equipment and the date of purchase.

## 商品に関するご相談窓口 / For product enquiry

- お問い合わせの際は器具銘板で器具形式をご確認のうえ、ご連絡ください。  
For enquiry, please quote us the product model found on the label on the product.
- 電話番号など、変更になる場合があります。ホームページでご確認ください。  
Our phone numbers printed in this manual may change. Please visit our homepage for the latest contact information.

## ASIAN STANLEY INTERNATIONAL CO.,LTD.

48/1 Moo 1 Kukwang Ladlumkaew, Pathumthanee 12140 Thailand  
TEL : +66 2 599 1260

## スタンレー電気株式会社

## STANLEY ELECTRIC CO.,LTD.

横浜サテライトセンター 〒225-0014 神奈川県横浜市青葉区荏田西2-14-1

Yokohama Satellite Center : 2-14-1 Edanishi, Aoba-ku, Yokohama-shi, Kanagawa, 225-0014 Japan  
TEL : +81 45 910 6629

**本社** 〒153-8636 東京都目黒区中目黒2-9-13

Head office : 2-9-13 Nakameguro, Meguro-ku, Tokyo, 153-8636 Japan  
TEL : +81 3 3710 2222